

105  
107

# AC Permanent Magnet Motors

Models 105, 107, 113

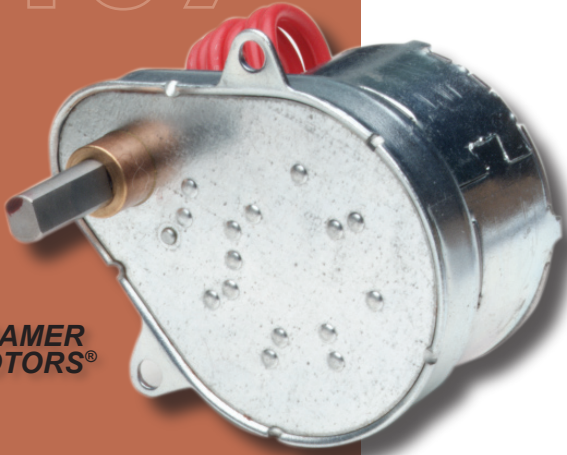

CRAMER  
MOTORS®

*The Cramer line of AC Permanent Magnet Motors offers application solutions requiring fast starts, fast stops where coasting of load is undesirable and low wattage operating power consumption.*

113

## Applications:

- Valve Drive Assemblies • Automatic Teller Machines
- POP Displays • Timing Control Systems

## Features:

- Maintains synchronous speeds
- High torque rating
- Fast starts and stops
- Low power consumption
- Clockwise and Counter Clockwise rotation available
- Lifetime lubrication
- Pear-shape and round gear case available

## Similar Products By Cramer:



DC Permanent Motors Model 800



Hysteresis Motors Model 6100

**CRAMER  
COMPANY**

Precision Timers and Motion Devices

105 Nutmeg Road South  
South Windsor, CT 06074 USA

P: 860.291.8402

F: 860.610.0897

cramer-motors.com

## Specifications: Rating Data (Ounce Inches @ 1 RPM)

Model	105	107	113
Starting Torque @ 1 RPM	300 oz. in.	30 oz. in.	60 oz. in.
Running Torque @ 1 RPM	300 oz. in.	60 oz. in.	60 oz. in.
Standard Voltages	24/120/240 VAC	24/120/240 VAC	24/120/240 VAC
Standard Frequency	60 Hz.	60 Hz.	60 Hz.
Power Input (Nominal)	2.7 Watts	1.5 Watts	2.7 Watts
Direction of Rotation	CW & CCW	CW & CCW	CW & CCW
Operating Temperature Range	-4°F to 131°F -20°C to 55°C	-4°F to 131°F -20°C to 55°C	-4°F to 131°F -20°C to 55°C
Clutches*	One- or Two-way	One- or Two-way	One- or Two-way
Gear Train Rating	Standard & Heavy Duty	Standard & Heavy Duty	Standard & Heavy Duty
Static**	90-160 oz. in.	90-160 oz. in.	90-160 oz. in.
Dynamic***	30-150 oz. in.	30-150 oz. in.	30-150 oz. in.
Standard Mounting	2 hole	2 hole	2 hole

\***Slip clutch** devices are built into a gear train to permit manual rotation of the output shaft. **One-way clutch** permits manual advances in the direction of powered shaft rotation only. **Two-way clutch** permits manual turning in either direction, but is not designed for continuous slippage and should not be relied upon to protect a gear train against excessive torque loads. \*\***Static torque** rating is the maximum static load that can be sustained without substantial risk of damage to the gear train. \*\*\***Dynamic torque** rating is the maximum load the gear train can drive continuously.

# AC Permanent Magnet Motors

## Pear-Shaped Gear Case:

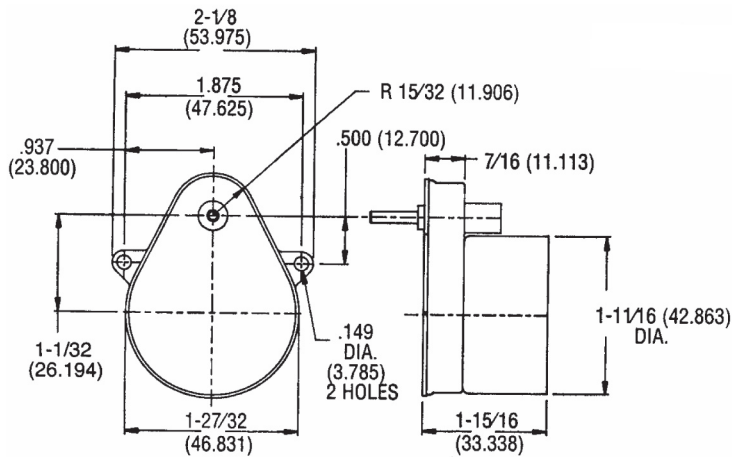

## Round-Shaped Gear Case:

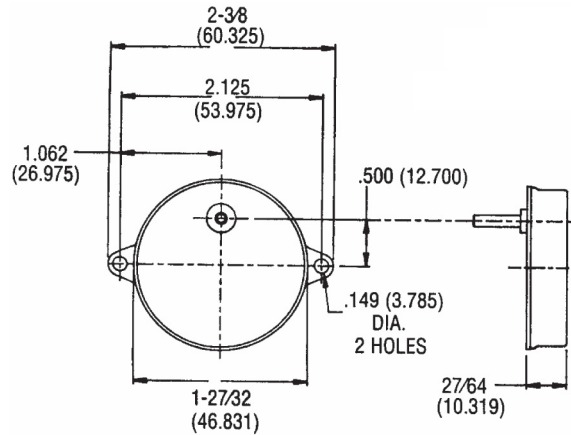

Dimensions: INCH [MM]

## Shaft Selection Data:

Dwg. No. 1  
ROUND SHAFT

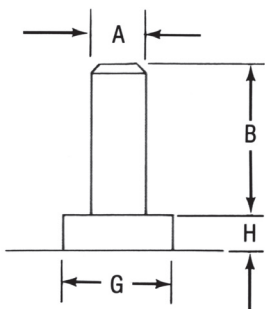

Dwg. No. 2  
FLATTED ROUND SHAFT

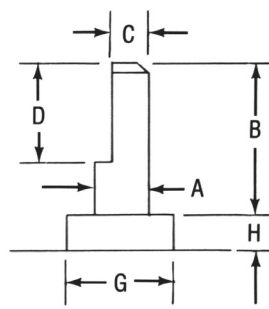

Dwg. No. 3  
KNURLED ROUND SHAFT

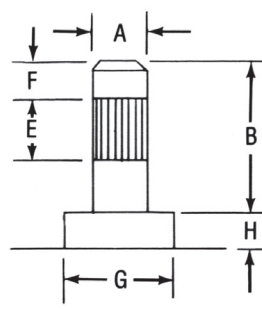

When selecting the required shaft for your application, please indicate the type of shaft needed—either round, flatted or knurled, including other key measurements below:

**Shaft diameter (A)**

**Shaft length (B)**

**Shaft width at flat (C) and length (D)**

**Knurl length (E) and knurl set back (F)**

**Bearing O.D. (G) and Bearing height (H)**

## Motor Selection:

When specifying a motor for meeting your application, Cramer Company requires information such as torque, speed requirements, voltage, shaft dimensions and shape, direction of rotation and other key performance values.

To assist you in specifying the requirements above, please visit [cramer-motors.com](http://cramer-motors.com) or call our sales staff and request a specification worksheet for completing the information.

**Warranty:** Cramer warrants its products against defective material or workmanship for a period of one year from the date of shipment from factory, providing product has been used in accordance with instructions and specified ratings. Consult factory for further details concerning our warranty policy.